



P.O. Box 58, Crystal City, MB R0K 0N0 / P.O Box 54, Sarles, ND 58372

Quick Start Guide – KIT400094 BOOM BLOWOUT KIT

Installation

Refer to operators manual for complete safety and operation info.

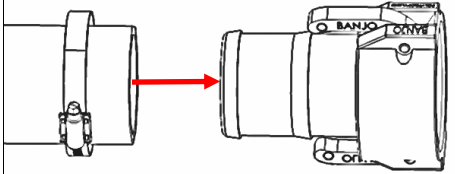
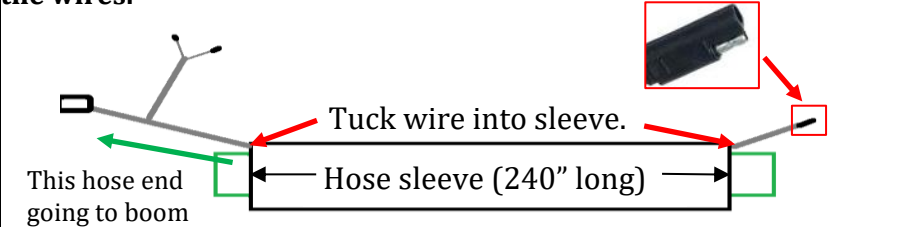
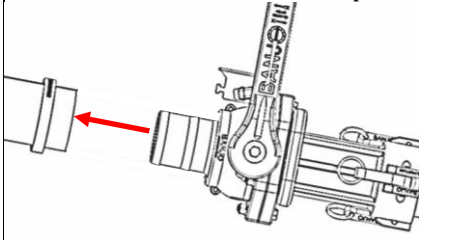
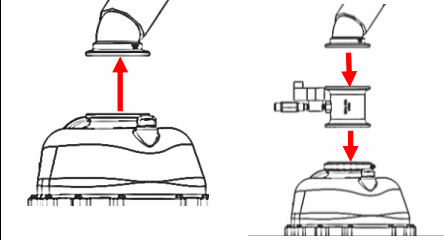
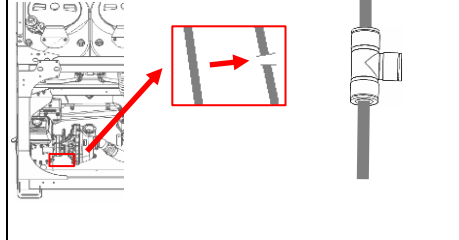
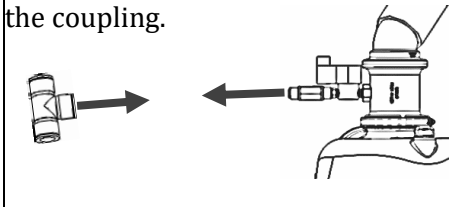
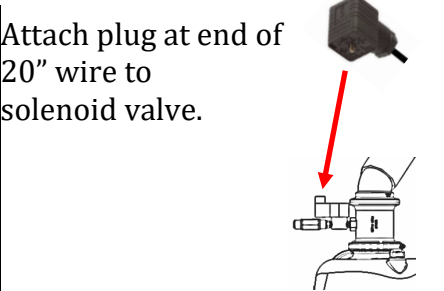
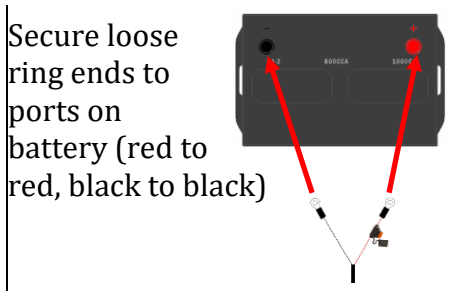
<p>1 -</p> <p>Remove quick disconnect fitting from end of boom hose, remove clamp as well.</p> 	<p>2 -</p> <p>Run hose through hose sleeve, using the newly empty end as the running end. Run the wire through the sleeve along with the hose. The end of the wire with the trailer plug should match the end of the hose with nothing. Tuck about 6-8" of the wire back into the hose sleeve on both sides. This will allow the hose to stretch without damaging the wires.</p> 	
<p>4 -</p> <p>Attach blowout valve to end of boom hose. Secure to hose with clamp. Secure sleeve to hose on this side with zip-tie. Secure sleeve to hose on opposite side under boom's U-bolt or with zip-tie.</p> 	<p>5 -</p> <p>Disconnect hose from pump, attach coupling in-between and re-connect using clamps. Use gaskets between the flanges.</p> 	<p>6 -</p> <p>Cut regulated air hose close to the coupling location, insert the new ends into the sides of the airline tee.</p> 
<p>7 -</p> <p>Use supplied 3/8ths airline to attach tee to appropriate valve on the coupling.</p> 	<p>8 -</p> <p>Attach plug at end of 20" wire to solenoid valve.</p> 	<p>9 -</p> <p>Secure loose ring ends to ports on battery (red to red, black to black)</p> 

DOC400062



P.O. Box 58, Crystal City, MB R0K 0N0 / P.O. Box 54, Sarles, ND 58372

Product Use

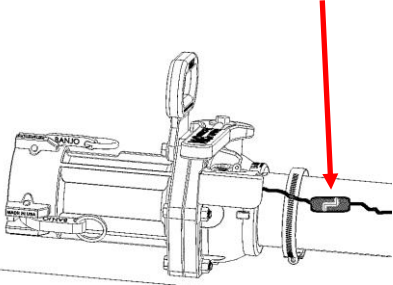
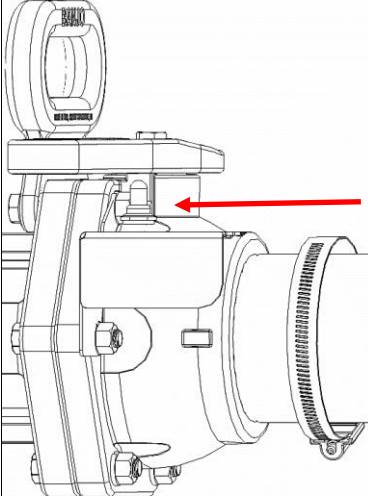
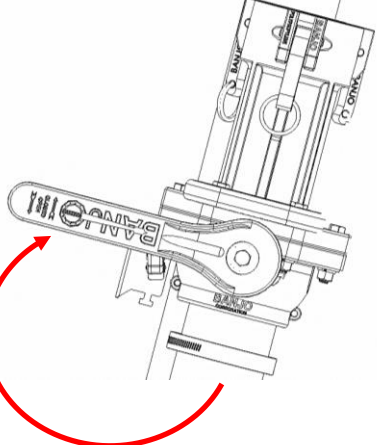
1 -	2 -	3 -
<p>Ensure the trailer plug coming out of the hose sleeve is attached to the trailer plug on the blowout valve</p> 	<p>After filling the sprayer, use the blowout valve to empty the hose. The switch activates the air purge.</p> 	<p>Once hose is empty, close ball valve and air purge will automatically shut off.</p> 

DOC400062

INNOVATIVE DESIGN • PARTNERS IN EFFICIENCY

866.264.8030 | PhiBer.ca